

OFFSHORE CONNECTION

LADY SMITH

Lady Smith is a Lochin 367 built by Goodchild Marine, renowned hull from lifeboats to pilot boats for its seaworthiness. She is a very capable boat and ideal for transfers, standby work and pilot duties. The cabin layout allows for 4 passengers to be seated in comfortable suspension seats. Plenty of seating in the main cabin and in the fore cabin. Previously built for the police, her spec is very high and a high finish. Fitted with a Goodchild recovery platform at the stern, 150kg davit and matesaver pole. Flybridge helm position. Fire pump hose and salvage pump capabilities. Can be used for towing also.

- **Category 2 MCA coding with Pilot Boat Endorsement**
- **Heavy duty fendering**
- **Large foredeck area for pilots**
- **12+3 passenger plus crew**
- **Heated cabin for the winter months**
- **Galley and heads**
- **2 berths**
- **Hadrian rail**
- **Goodchild recovering stern platform**
- **Fire fighting pump and salvage pump capabilities**
- **Excellent sea keeping capabilities**
- **Towing available**



LADY SMITH SPECIFICATIONS

MANUFACTURER		Lochin 367, Goodchild Marine
HULL		GRP
LENGTH		11.1m
BREADTH		4m
DRAFT		1.2m
ENGINES		Cummins QSB 5.9 x2 425 HP (Diesel)
DRIVE		Shafts
MCA CATEGORY		Category 2, with pilot boat coding
ELECTRONICS		Simrad Chartplotter, Radar 4G & 6Kw, Sonar with side and forward scanning, AIS, Auto helm, Simrad vhfs with Icom handhelds, Loud hailer, Airmar weather station, all round CCTV with engine room cameras, 240 v throughout.
SPEED (Knots)		22 cruising
SEATING		12+3 seating

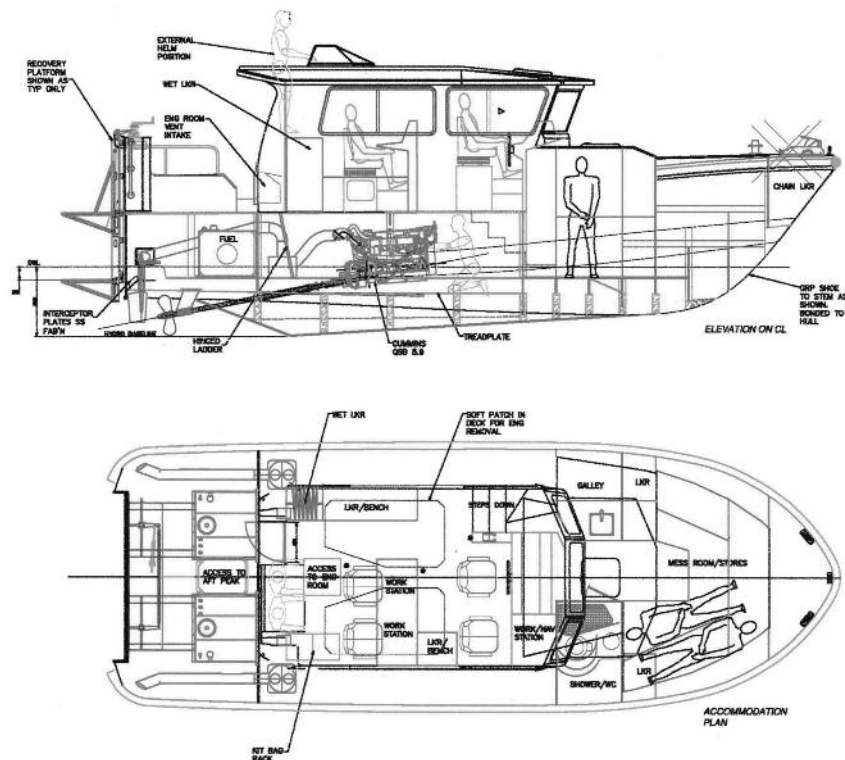

All skippers and crew are experienced and qualified to carry out a range of different services. All requirements can be catered for. Please contact us to charter Lady Smith.

Please contact us if you require any further information

OFFSHORE CONNECTION *(is the commercial sector of Coastal Connection LLP)*

t: 01631 565 833 m: 07919 615210 – 24/7
 info@offshore-connection.co.uk

www.offshore-connection.co.uk

